

LM78LXX Series LM78LXX Series 3-Terminal Positive Regulators 3-Terminal Positive Regulators

General Description

The LM78LXX series of three terminal positive regulators is available with several fixed output voltages making them useful in a wide range of applications. When used as a zener diode/resistor combination replacement, the LM78LXX usually results in an effective output impedance improvement of two orders of magnitude, and lower quiescent current. These regulators can provide local on card regulation, eliminating the distribution problems associated with single point regulation. The voltages available allow the LM78LXX to be used in logic systems, instrumentation, HiFi, and other solid state electronic equipment.

The LM78LXX is available in the plastic TO-92 (Z) package, the plastic SO-8 (M) package and a chip sized package (8-Bump micro SMD) using National's micro SMD package technology. With adequate heat sinking the regulator can deliver 100 mA output current. Current limiting is included to limit the peak output current to a safe value. Safe area pro-

tection for the output transistors is provided to limit internal power dissipation. If internal power dissipation becomes too high for the heat sinking provided, the thermal shutdown circuit takes over preventing the IC from overheating.

Features

- LM78L05 in micro SMD package
- Output voltage tolerances of $\pm 5\%$ over the temperature range
- Output current of 100 mA
- Internal thermal overload protection
- Output transistor safe area protection
- Internal short circuit current limit
- Available in plastic TO-92 and plastic SO-8 low profile packages
- No external components
- Output voltages of 5.0V, 6.2V, 8.2V, 9.0V, 12V, 15V

Connection Diagrams

**SO-8 Plastic (M)
(Narrow Body)**

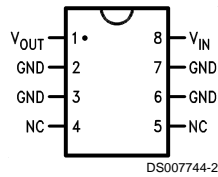

Top View

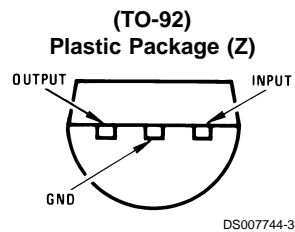

Bottom View

8-Bump micro SMD

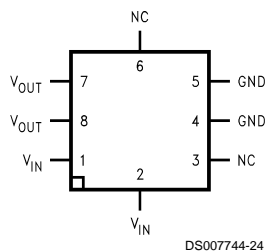

**Top View
(Bump Side Down)**

micro SMD Marking Orientation

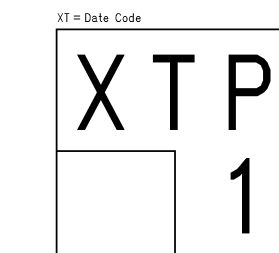

Pin 1 Corner
Pin 1 is identified by lower left corner with respect to the text.

Top View

Absolute Maximum Ratings (Note 1)

Operating Junction Temperature

If Military/Aerospace specified devices are required, please contact the National Semiconductor Sales Office/Distributors for availability and specifications.

Power Dissipation (Note 5)	Internally Limited
Input Voltage	35V
Storage Temperature	-65°C to +150°C

SO-8	0°C to 125°C
micro SMD	-40°C to 85°C
Soldering Information	
Infrared or Convection (20 sec.)	235°C
Wave Soldering (10 sec.)	260°C (lead time)
ESD Susceptibility (Note 2)	1kV

LM78LXX Electrical Characteristics Limits in standard typeface are for $T_J = 25^\circ\text{C}$, **Bold typeface applies over 0°C to 125°C for SO-8 package and -40°C to 85°C for micro SMD package.** Limits are guaranteed by production testing or correlation techniques using standard Statistical Quality Control (SQC) methods. Unless otherwise specified: $I_O = 40\text{ mA}$, $C_I = 0.33\text{ }\mu\text{F}$, $C_O = 0.1\text{ }\mu\text{F}$.

LM78L05

Unless otherwise specified, $V_{IN} = 10\text{V}$

Symbol	Parameter	Conditions	Min	Typ	Max	Units
V_O	Output Voltage		4.8	5	5.2	V
		$7\text{V} \leq V_{IN} \leq 20\text{V}$ $1\text{ mA} \leq I_O \leq 40\text{ mA}$ (Note 3)	4.75		5.25	
		$1\text{ mA} \leq I_O \leq 70\text{ mA}$ (Note 3)	4.75		5.25	
ΔV_O	Line Regulation	$7\text{V} \leq V_{IN} \leq 20\text{V}$		18	75	mV
		$8\text{V} \leq V_{IN} \leq 20\text{V}$		10	54	
ΔV_O	Load Regulation	$1\text{ mA} \leq I_O \leq 100\text{ mA}$		20	60	mV
		$1\text{ mA} \leq I_O \leq 40\text{ mA}$		5	30	
I_Q	Quiescent Current			3	5	mA
ΔI_Q	Quiescent Current Change	$8\text{V} \leq V_{IN} \leq 20\text{V}$ $1\text{ mA} \leq I_O \leq 40\text{ mA}$			1.0 0.1	
V_n	Output Noise Voltage	$f = 10\text{ Hz to } 100\text{ kHz}$ (Note 4)		40		μV
$\frac{\Delta V_{IN}}{\Delta V_{OUT}}$	Ripple Rejection	$f = 120\text{ Hz}$ $8\text{V} \leq V_{IN} \leq 16\text{V}$	47	62		dB
I_{PK}	Peak Output Current			140		mA
$\frac{\Delta V_O}{\Delta T}$	Average Output Voltage Tempco	$I_O = 5\text{ mA}$		-0.65		$\text{mV}/^\circ\text{C}$
$V_{IN}(\text{Min})$	Minimum Value of Input Voltage Required to Maintain Line Regulation			6.7	7	V
θ_{JA}	Thermal Resistance (8-Bump micro SMD)			230.9		$^\circ\text{C}/\text{W}$

LM78L62AC

Unless otherwise specified, $V_{IN} = 12\text{V}$

Symbol	Parameter	Conditions	Min	Typ	Max	Units
V_O	Output Voltage		5.95	6.2	6.45	V
		$8.5\text{V} \leq V_{IN} \leq 20\text{V}$ $1\text{ mA} \leq I_O \leq 40\text{ mA}$ (Note 3)	5.9		6.5	
		$1\text{ mA} \leq I_O \leq 70\text{ mA}$ (Note 3)	5.9		6.5	
ΔV_O	Line Regulation	$8.5\text{V} \leq V_{IN} \leq 20\text{V}$		65	175	mV
		$9\text{V} \leq V_{IN} \leq 20\text{V}$		55	125	
ΔV_O	Load Regulation	$1\text{ mA} \leq I_O \leq 100\text{ mA}$		13	80	mV
		$1\text{ mA} \leq I_O \leq 40\text{ mA}$		6	40	

LM78L62AC (Continued)

Unless otherwise specified, $V_{IN} = 12V$

Symbol	Parameter	Conditions	Min	Typ	Max	Units
I_Q	Quiescent Current			2	5.5	mA
ΔI_Q	Quiescent Current Change	$8V \leq V_{IN} \leq 20V$ $1 mA \leq I_O \leq 40 mA$			1.5 0.1	
V_n	Output Noise Voltage	$f = 10 Hz$ to 100 kHz (Note 4)		50		μV
$\frac{\Delta V_{IN}}{\Delta V_{OUT}}$	Ripple Rejection	$f = 120 Hz$ $10V \leq V_{IN} \leq 20V$	40	46		dB
I_{PK}	Peak Output Current			140		mA
$\frac{\Delta V_O}{\Delta T}$	Average Output Voltage Tempco	$I_O = 5 mA$		-0.75		mV/°C
$V_{IN} (Min)$	Minimum Value of Input Voltage Required to Maintain Line Regulation			7.9		V

LM78L82AC

Unless otherwise specified, $V_{IN} = 14V$

Symbol	Parameter	Conditions	Min	Typ	Max	Units
V_O	Output Voltage		7.87	8.2	8.53	V
		$11V \leq V_{IN} \leq 23V$ $1 mA \leq I_O \leq 40 mA$ (Note 3)	7.8		8.6	
		$1 mA \leq I_O \leq 70 mA$ (Note 3)	7.8		8.6	
ΔV_O	Line Regulation	$11V \leq V_{IN} \leq 23V$		80	175	mV
		$12V \leq V_{IN} \leq 23V$		70	125	
ΔV_O	Load Regulation	$1 mA \leq I_O \leq 100 mA$		15	80	mV
		$1 mA \leq I_O \leq 40 mA$		8	40	
I_Q	Quiescent Current			2	5.5	mA
ΔI_Q	Quiescent Current Change	$12V \leq V_{IN} \leq 23V$ $1 mA \leq I_O \leq 40 mA$			1.5 0.1	
V_n	Output Noise Voltage	$f = 10 Hz$ to 100 kHz (Note 4)		60		μV
$\frac{\Delta V_{IN}}{\Delta V_{OUT}}$	Ripple Rejection	$f = 120 Hz$ $12V \leq V_{IN} \leq 22V$	39	45		dB
I_{PK}	Peak Output Current			140		mA
$\frac{\Delta V_O}{\Delta T}$	Average Output Voltage Tempco	$I_O = 5 mA$		-0.8		mV/°C
$V_{IN} (Min)$	Minimum Value of Input Voltage Required to Maintain Line Regulation			9.9		V

LM78L09AC

Unless otherwise specified, $V_{IN} = 15V$

Symbol	Parameter	Conditions	Min	Typ	Max	Units
V_O	Output Voltage		8.64	9.0	9.36	V
		$11.5V \leq V_{IN} \leq 24V$ $1 mA \leq I_O \leq 40 mA$ (Note 3)	8.55		9.45	
		$1 mA \leq I_O \leq 70 mA$ (Note 3)	8.55		9.45	

LM78L09AC (Continued)

Unless otherwise specified, $V_{IN} = 15V$

Symbol	Parameter	Conditions	Min	Typ	Max	Units
ΔV_O	Line Regulation	$11.5V \leq V_{IN} \leq 24V$		100	200	mV
		$13V \leq V_{IN} \leq 24V$		90	150	
ΔV_O	Load Regulation	$1 mA \leq I_O \leq 100 mA$		20	90	mV
		$1 mA \leq I_O \leq 40 mA$		10	45	
I_Q	Quiescent Current			2	5.5	mA
ΔI_Q	Quiescent Current Change	$11.5V \leq V_{IN} \leq 24V$			1.5	
		$1 mA \leq I_O \leq 40 mA$			0.1	
V_n	Output Noise Voltage			70		μV
$\frac{\Delta V_{IN}}{\Delta V_{OUT}}$	Ripple Rejection	$f = 120 Hz$ $15V \leq V_{IN} \leq 25V$	38	44		dB
I_{PK}	Peak Output Current			140		mA
$\frac{\Delta V_O}{\Delta T}$	Average Output Voltage Tempco	$I_O = 5 mA$		-0.9		mV/°C
$V_{IN} (Min)$	Minimum Value of Input Voltage Required to Maintain Line Regulation			10.7		V

LM78L12AC

Unless otherwise specified, $V_{IN} = 19V$

Symbol	Parameter	Conditions	Min	Typ	Max	Units
V_O	Output Voltage		11.5	12	12.5	V
		$14.5V \leq V_{IN} \leq 27V$ $1 mA \leq I_O \leq 40 mA$ (Note 3)	11.4		12.6	
		$1 mA \leq I_O \leq 70 mA$ (Note 3)	11.4		12.6	
ΔV_O	Line Regulation	$14.5V \leq V_{IN} \leq 27V$		30	180	mV
		$16V \leq V_{IN} \leq 27V$		20	110	
ΔV_O	Load Regulation	$1 mA \leq I_O \leq 100 mA$		30	100	mV
		$1 mA \leq I_O \leq 40 mA$		10	50	
I_Q	Quiescent Current			3	5	mA
ΔI_Q	Quiescent Current Change	$16V \leq V_{IN} \leq 27V$			1	
		$1 mA \leq I_O \leq 40 mA$			0.1	
V_n	Output Noise Voltage			80		μV
$\frac{\Delta V_{IN}}{\Delta V_{OUT}}$	Ripple Rejection	$f = 120 Hz$ $15V \leq V_{IN} \leq 25$	40	54		dB
I_{PK}	Peak Output Current			140		mA
$\frac{\Delta V_O}{\Delta T}$	Average Output Voltage Tempco	$I_O = 5 mA$		-1.0		mV/°C
$V_{IN} (Min)$	Minimum Value of Input Voltage Required to Maintain Line Regulation			13.7	14.5	V

LM78L15AC

Unless otherwise specified, $V_{IN} = 23V$

Symbol	Parameter	Conditions	Min	Typ	Max	Units
V_O	Output Voltage		14.4	15.0	15.6	V
		$17.5V \leq V_{IN} \leq 30V$ $1\text{ mA} \leq I_O \leq 40\text{ mA}$ (Note 3)	14.25		15.75	
		$1\text{ mA} \leq I_O \leq 70\text{ mA}$ (Note 3)	14.25		15.75	
ΔV_O	Line Regulation	$17.5V \leq V_{IN} \leq 30V$		37	250	mV
		$20V \leq V_{IN} \leq 30V$		25	140	
ΔV_O	Load Regulation	$1\text{ mA} \leq I_O \leq 100\text{ mA}$		35	150	mV
		$1\text{ mA} \leq I_O \leq 40\text{ mA}$		12	75	
I_Q	Quiescent Current			3	5	mA
ΔI_Q	Quiescent Current Change	$20V \leq V_{IN} \leq 30V$ $1\text{ mA} \leq I_O \leq 40\text{ mA}$			1 0.1	
V_n	Output Noise Voltage			90		μV
$\frac{\Delta V_{IN}}{\Delta V_{OUT}}$	Ripple Rejection	$f = 120\text{ Hz}$ $18.5V \leq V_{IN} \leq 28.5V$	37	51		dB
I_{PK}	Peak Output Current			140		mA
$\frac{\Delta V_O}{\Delta T}$	Average Output Voltage Tempco	$I_O = 5\text{ mA}$		-1.3		mV/°C
$V_{IN}(\text{Min})$	Minimum Value of Input Voltage Required to Maintain Line Regulation			16.7	17.5	V

Note 1: Absolute Maximum Ratings indicate limits beyond which damage to the device may occur. Electrical specifications do not apply when operating the device outside of its stated operating conditions.

Note 2: Human body model, 1.5 k Ω in series with 100 pF.

Note 3: Power dissipation $\leq 0.75W$.

Note 4: Recommended minimum load capacitance of 0.01 μF to limit high frequency noise.

Note 5: Typical thermal resistance values for the packages are:

Z Package: $\theta_{JC} = 60\text{ }^\circ\text{C/W}$, $\theta_{JA} = 230\text{ }^\circ\text{C/W}$

M Package: $\theta_{JA} = 180\text{ }^\circ\text{C/W}$

micro SMD Package: $\theta_{JA} = 230.9\text{ }^\circ\text{C/W}$

Typical Performance Characteristics

Maximum Average Power Dissipation (Z Package)

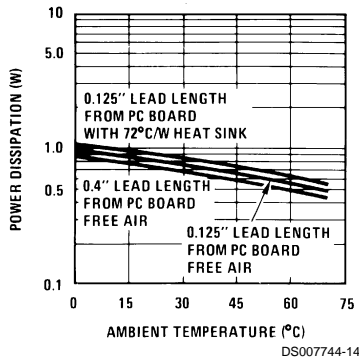

Peak Output Current

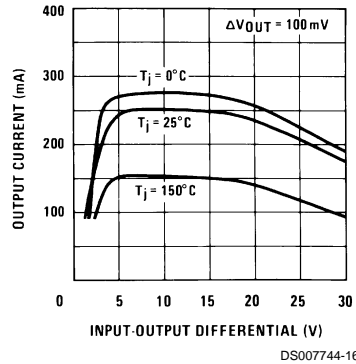

Dropout Voltage

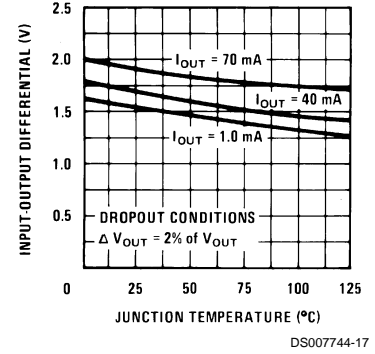

Ripple Rejection

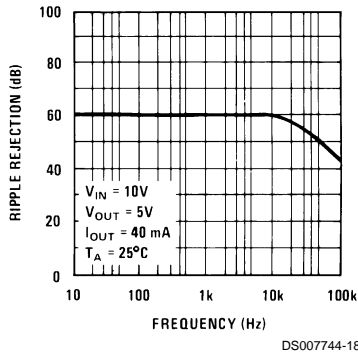

Output Impedance

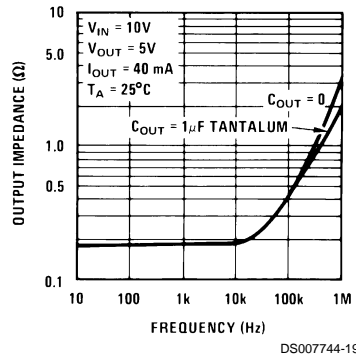

Quiescent Current

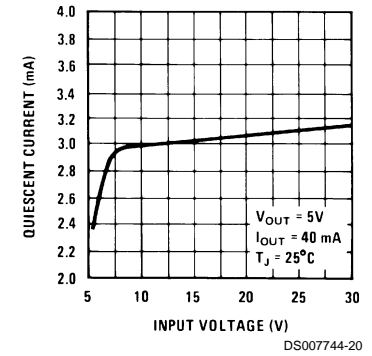

Quiescent Current

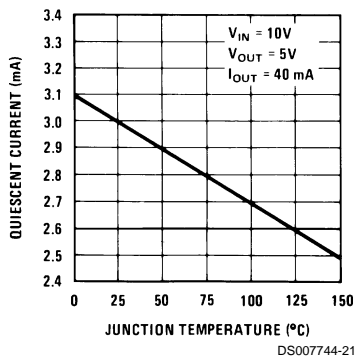

Equivalent Circuit

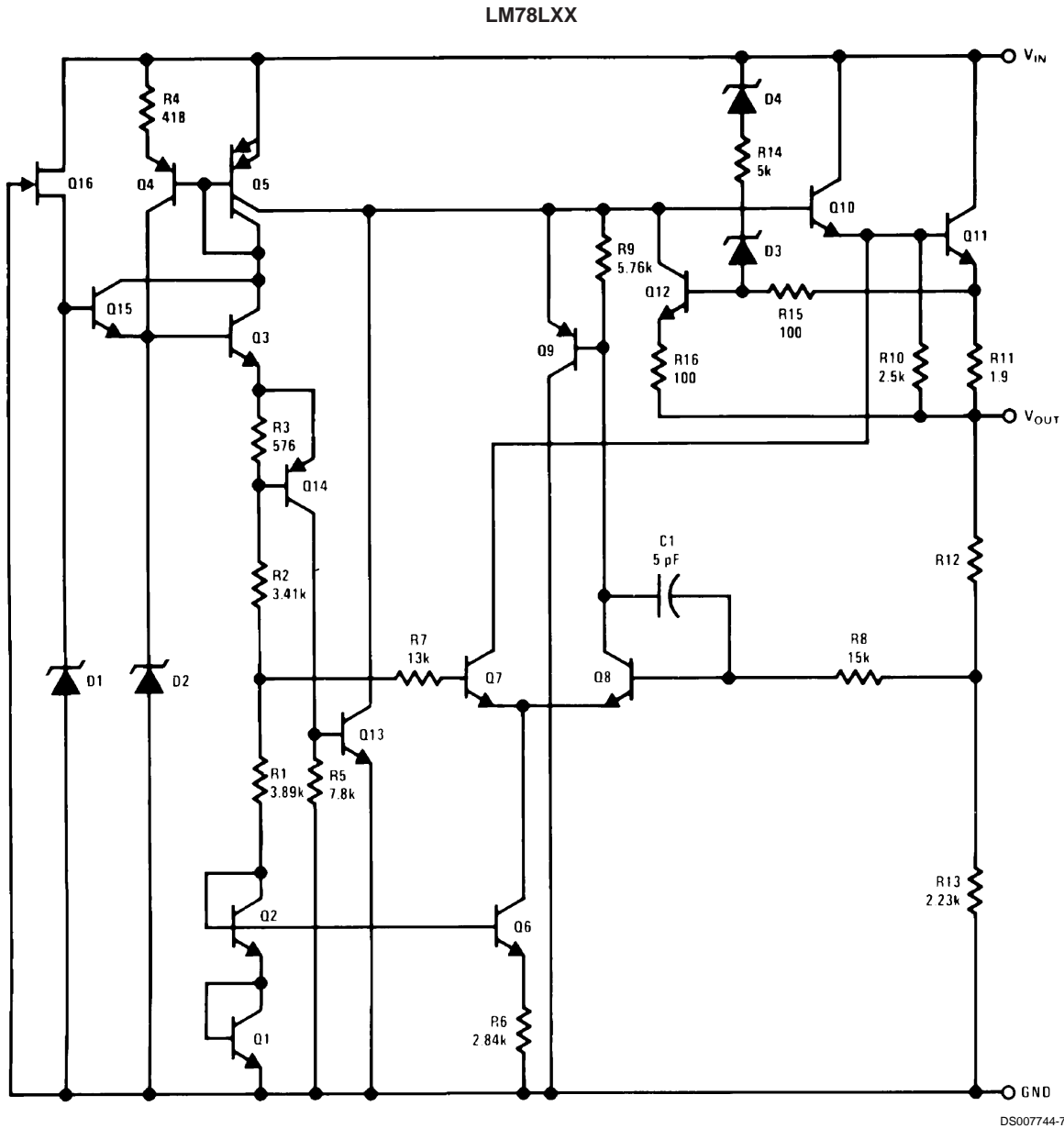

Typical Applications

Fixed Output Regulator

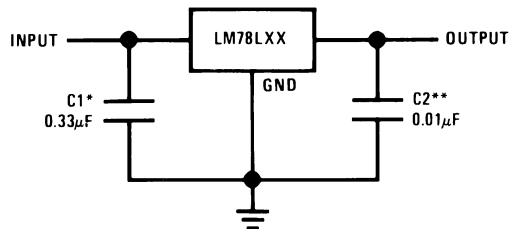

*Required if the regulator is located more than 3" from the power supply filter.

**See (Note 4) in the electrical characteristics table.

Typical Applications (Continued)

Adjustable Output Regulator

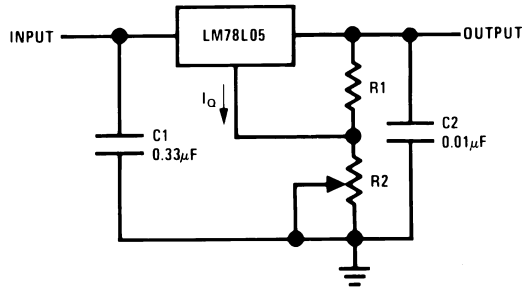

DS007744-9

$V_{OUT} = 5V + (5V/R1 + I_Q) R2$
 $5V/R1 > 3 I_Q$, load regulation (L_r) $\approx [(R1 + R2)/R1]$ (L_r of LM78L05)

Current Regulator

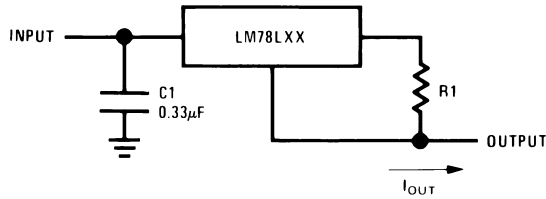

DS007744-10

$I_{OUT} = (V_{OUT}/R1) + I_Q$
 $>I_Q = 1.5 \text{ mA}$ over line and load changes

5V, 500 mA Regulator with Short Circuit Protection

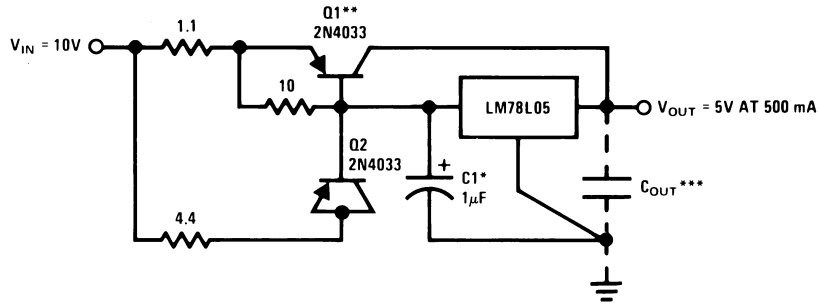

DS007744-11

*Solid tantalum.
 **Heat sink Q1.
 ***Optional: Improves ripple rejection and transient response.
 Load Regulation: 0.6% $0 \leq I_L \leq 250 \text{ mA}$ pulsed with $t_{ON} = 50 \text{ ms}$.

$\pm 15V$, 100 mA Dual Power Supply

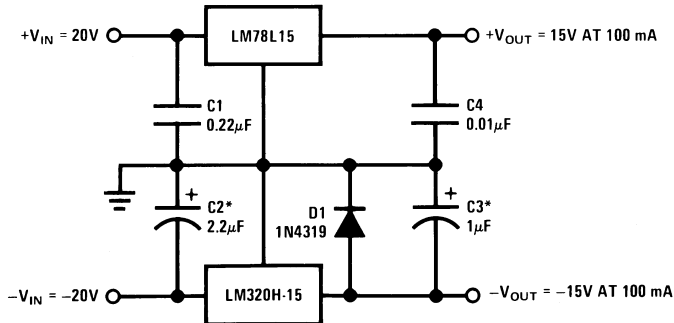

DS007744-12

*Solid tantalum.

Typical Applications (Continued)

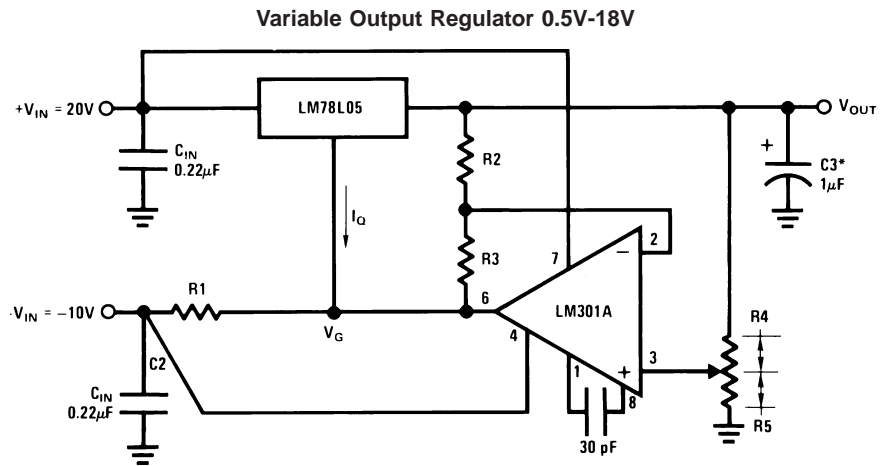

DS007744-13

*Solid tantalum.

$$V_{OUT} = V_G + 5V, R1 = (-V_{IN}/I_Q \text{ LM78L05})$$

$$V_{OUT} = 5V (R2/R4) \text{ for } (R2 + R3) = (R4 + R5)$$

$$\text{A } 0.5V \text{ output will correspond to } (R2/R4) = 0.1 \text{ } (R3/R4) = 0.9$$

Physical Dimensions inches (millimeters) unless otherwise noted

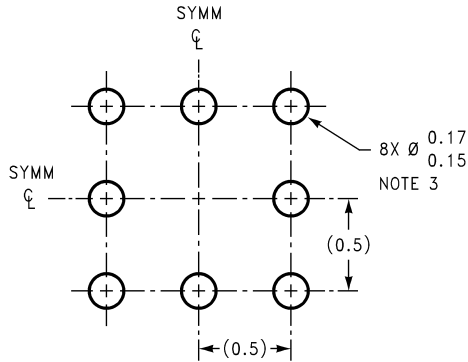

LAND PATTERN RECOMMENDATION

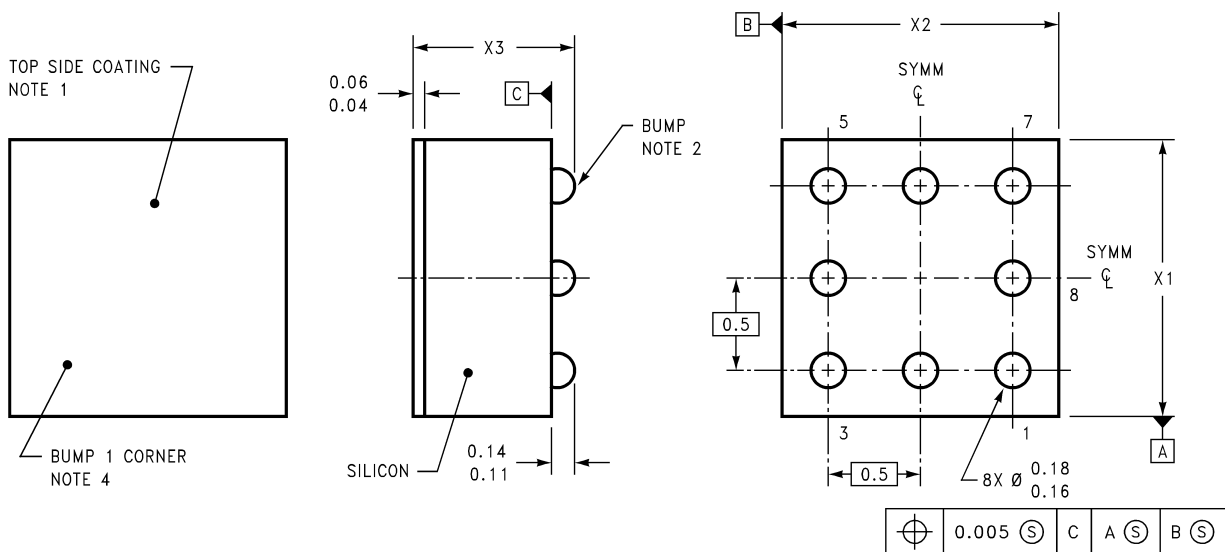

DIMENSIONS ARE IN MILLIMETERS

BPA08XXX (REV A)

NOTES: UNLESS OTHERWISE SPECIFIED

1. EPOXY COATING
2. 63Sn/37Pb EUTECTIC BUMP
3. RECOMMEND NON-SOLDER MASK DEFINED LANDING PAD.
4. PIN 1 IS ESTABLISHED BY LOWER LEFT CORNER WITH RESPECT TO TEXT ORIENTATION. REMAINING PINS ARE NUMBERED COUNTERCLOCKWISE.
5. XXX IN DRAWING NUMBER REPRESENTS PACKAGE SIZE VARIATION WHERE X_1 IS PACKAGE WIDTH, X_2 IS PACKAGE LENGTH AND X_3 IS PACKAGE HEIGHT.
6. REFERENCE JEDEC REGISTRATION MO-211, VARIATION BC.

8-Bump micro SMD
Order Number LM78L05IBP or LM78L05IBPX
NS Package Number BPA08AAA
 $X_1 = 1.285$ $X_2 = 1.285$ $X_3 = 0.7$

Physical Dimensions inches (millimeters) unless otherwise noted (Continued)

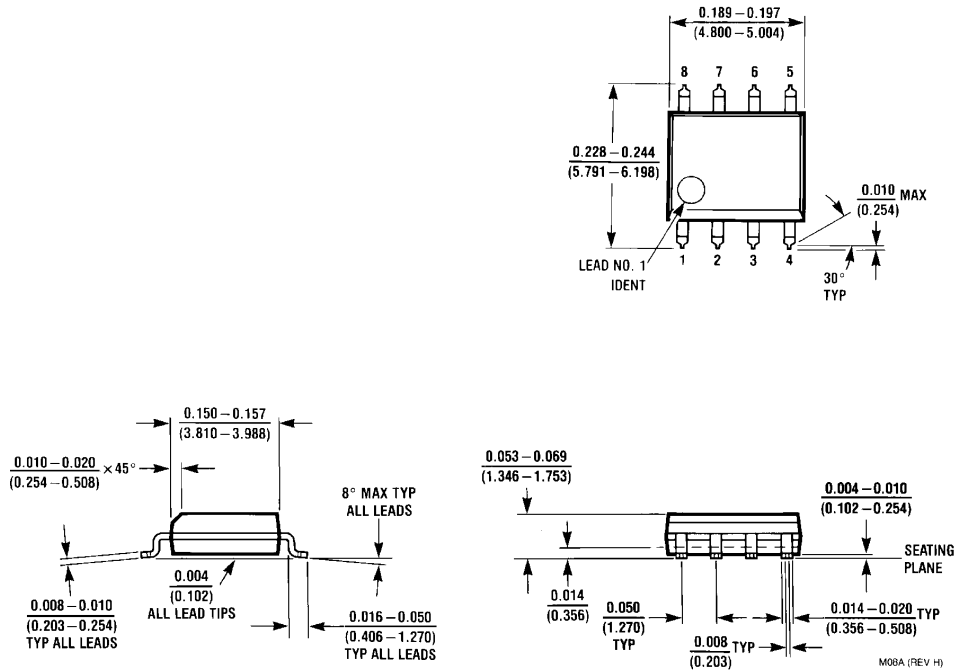

S.O. Package (M)
Order Number LM78L05ACM, LM78L12ACM or LM78L15ACM
NS Package Number M08A

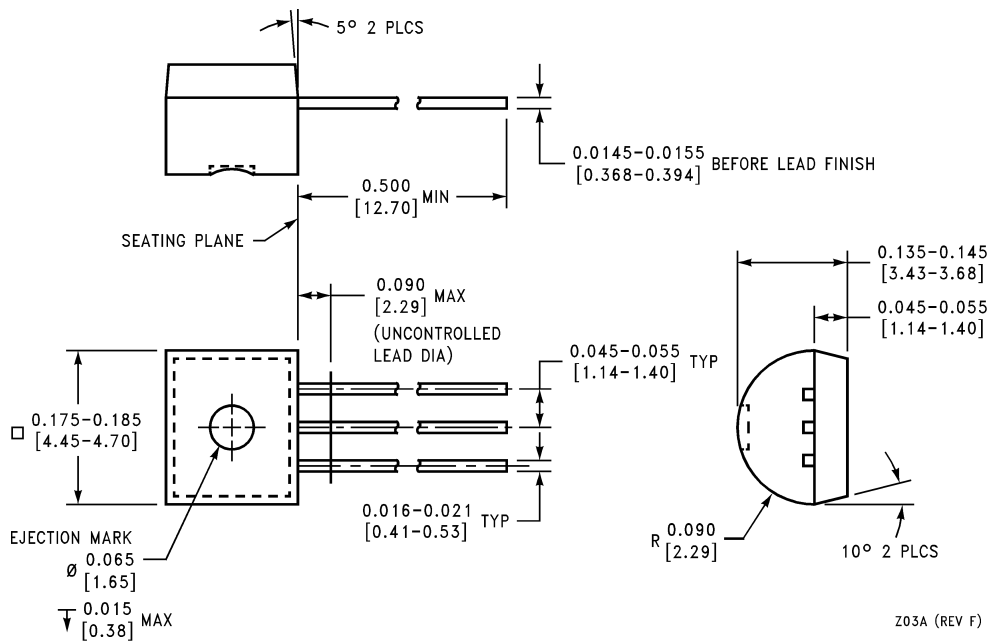

Molded Offset TO-92 (Z)
Order Number LM78L05ACZ, LM78L09ACZ, LM78L12ACZ,
LM78L15ACZ, LM78L62ACZ or LM78L82ACZ
NS Package Number Z03A

IMPORTANT NOTICE – PLEASE READ CAREFULLY
SZGKT Microelectronics NV and its subsidiaries reserve the right to make changes, corrections, enhancements, modifications, and improvements to SZGKT.